

Technical data sheet

Accessory mounting box, double

Item number: 6288611

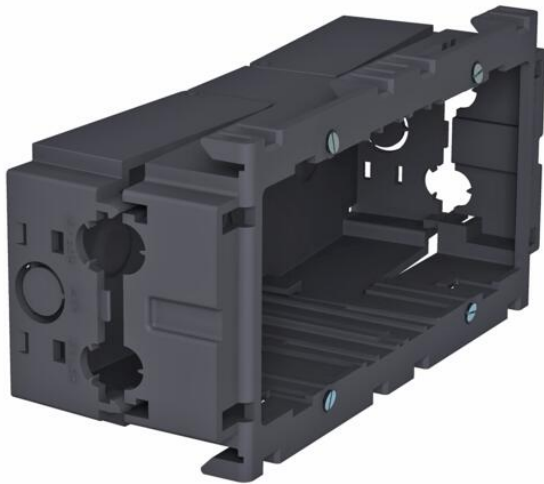

Front locking accessory mounting box for standard switch ranges for the installation of two individual installation devices or a multiple protective contact socket. With unfolding, and also removable, base for time-saving cable connection and with feed openings for cable diameters of up to 14 mm. Halogen-free version. Vertical fixing track 60 mm.



PA Polyamide

Master data

Item number	6288611
Type	71GD7
Description 1	Accessory mounting box
Description 2	double
Manufacturer	OBO
Dimension	160x76x51
Colour	Iron grey; RAL 7011
Material	Polyamide
Smallest sales unit	2
Unit of quantity	Piece
Weight	11 kg
Weight unit	kg/100 pc.

Technical data

Number of units	2
Version for	Closed
Fastening track	Other
Halogen-free	yes
With connection compartment	yes
Box mounting type	Front
Accessory mounting type	Lock
Strain relief option	no